

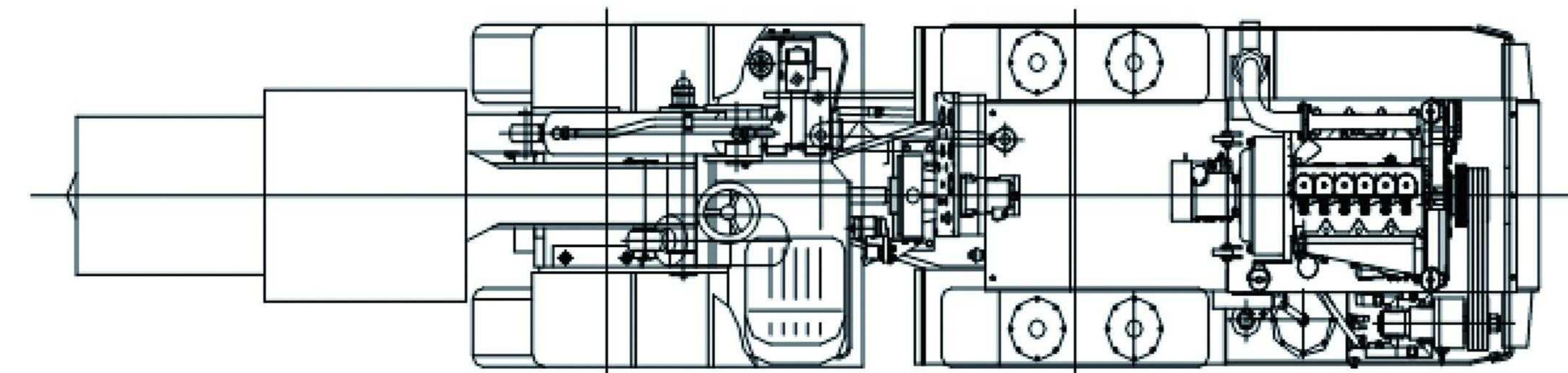

FKPS-100 Mobile Rack Breaker

General Dimension

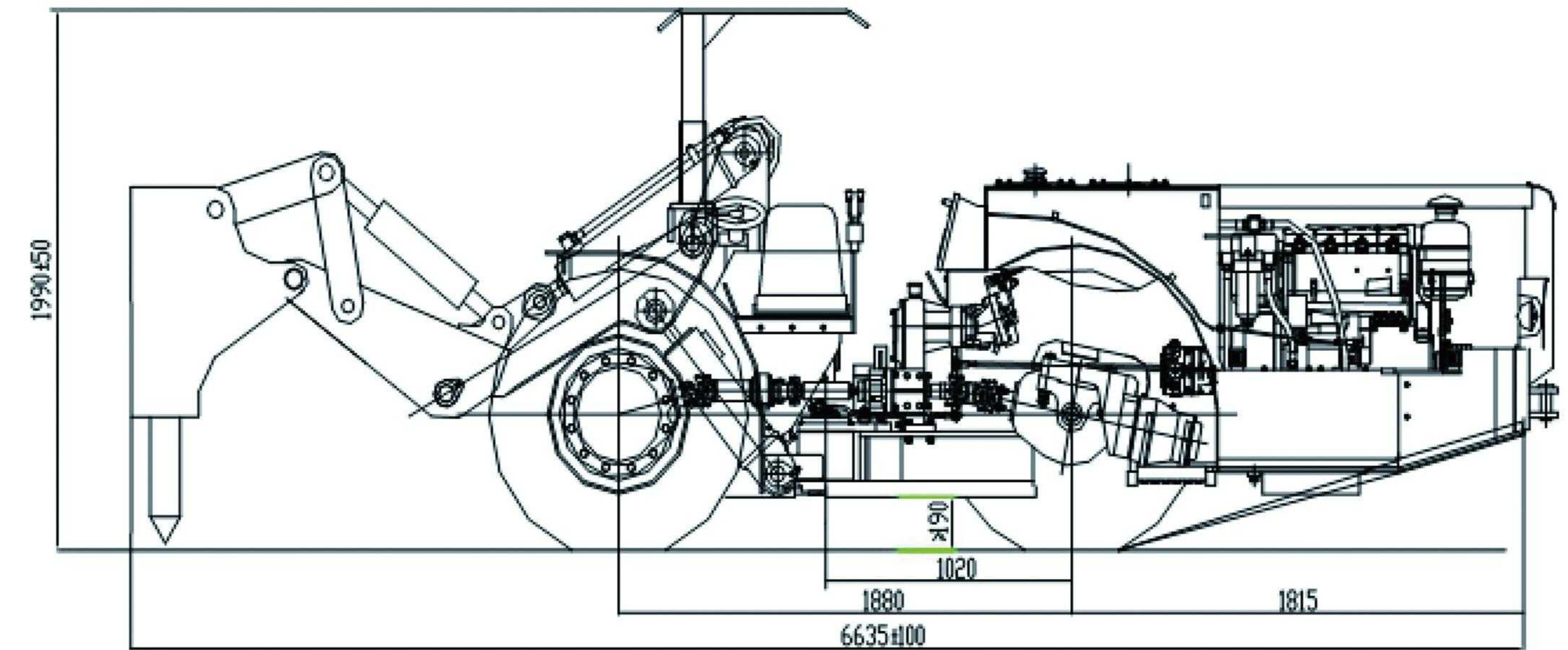

Main Features

- Main parts are imported top brand, like Deutz Engine, Sauer PV pumps and motors, Parker pump and valves etc.;
- Brake system is equipped with Forceps disc, hydraulic release and spring brake, supply better braking performance; Central articulated full hydraulic steering.
- Tailor made size and optional parts for customers to choose: remote control, ejector bucket etc.

FKPS-100 Mobile Rack Breaker



Technical Parameters

Diesel Engine

- Brand Germany DEUTZ
- Model F4L912W(Replaceable)
- Type Air cooling
- Rated Power 63KW/2300rpm

Hydraulic Pump

- Brand SAUER
- Model PV22
- Type..... Fully reversible variable piston pump

Hydraulic Motor

- Brand SAUER
- Model MV22
- Type..... Imported Variable piston motor

Transfer case

- Type Fixed axis helical gear drive
- Reduction ratio 2.643

Drive Axle

- Brand Focor
- Reduction ratio 25.868

Braking System

- Type Forceps disc, hydraulic release and spring brake

Driver Cabin

- Side-seat layout with good visionYES
- Closed Cabin with air conditioner.....for optional
- High strength protective compartment, with adjustable height

Breaker

- Brand SB50

Electric System

- Working voltage24V (consisted of two 12v batteries)

Fire System

- Manual Fire extinguisher YES
- Centralized Fire extinguisher For optional

Control system

- Manual control YES

General Parameter

- Impacting frequency 578-728 b.p.m
- Impactor diameter 100mm
- Impactor length 1760mmmm
- Impacting force 3000 pound
- Length 6635mm
- Width 1250mm
- Height(cabin) 1990mm
- Swing angle arm 70 °
- Wheelbase 1880mm
- Min. Ground clearance 195mm
- Departure angle 15 °
- Steering angle left/right 38 °
- Rear axle swing ± 6.5 °
- Min. Turning radius inner 2100mm
- Min. Turning radius Outer 4548mm

Loader Weight and Load Capacity

- Breaker weight 7000 kg

Traveling Performance

- Forward/backward 0-9.5 km/h
- Grade ability 30%
- Tyre size 10.00-20
- Tyre pressure 0.6-0.7 MPa

Hydraulic System Pressure

- Working pump capacity 63 ml/r
- Working rated pressure 16 MPa
- Steering pump capacity 16 ml/r
- Steering rated pressure 12.5 MPa

Oil tank volume

- Diesel oil tank 60L
- Hydraulic oil tank 120L

Hydraulic System

- Type Working system, steering system braking system, Oil filling and acceleration system

Lubrication System

- Manual lubrication YES
- Centralized lubrication For optional