

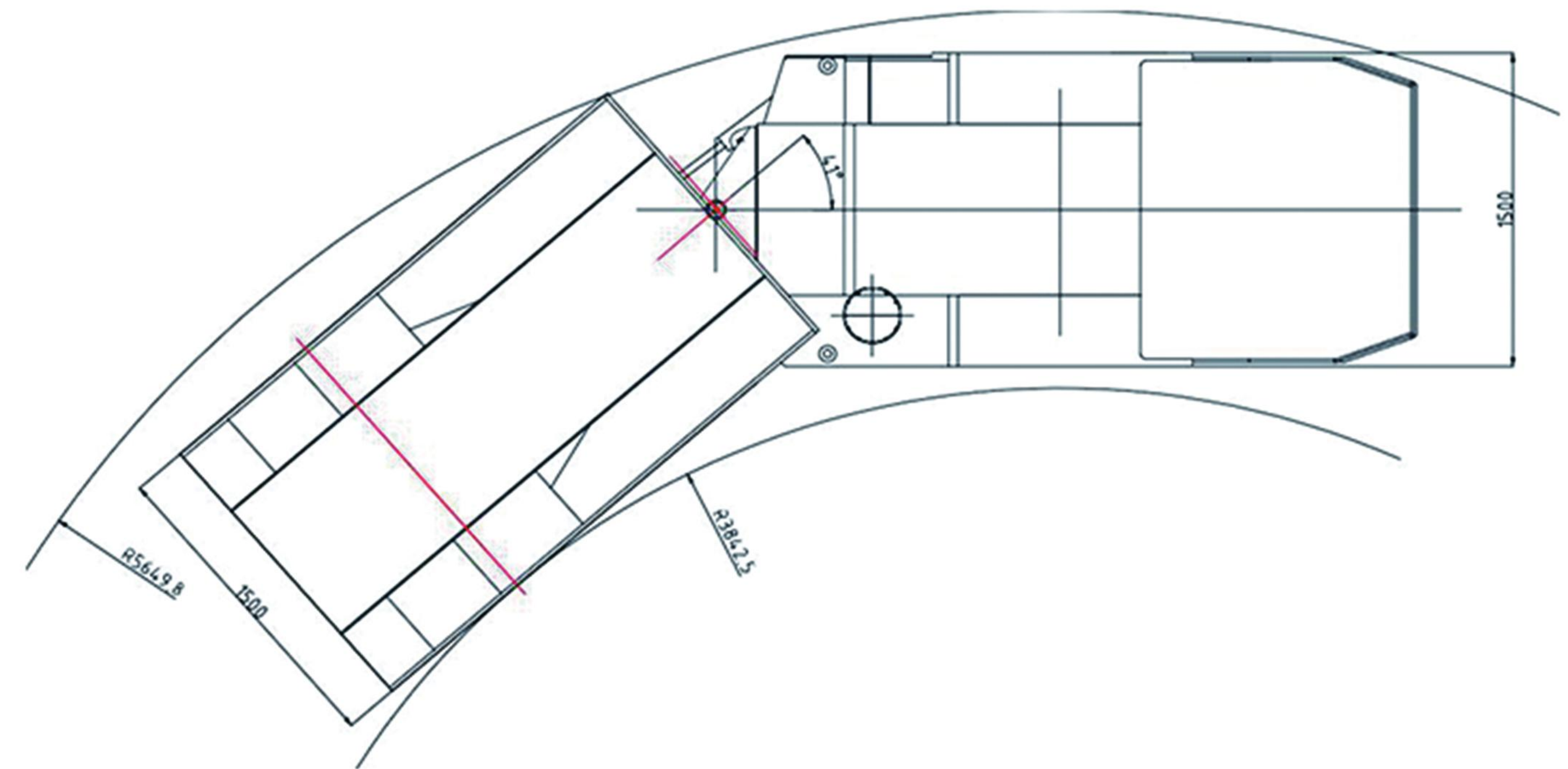

## Main Features

- Main parts are imported top brand, like Deutz Engine, DANA torque converter, transmission, Parker pump and valves etc.;
- Braking System consisted of Working brake and Stop brake, with Fully enclosed and Multi-disc wet hydraulic brake, Stop brake with spring brake;
- Tailor made size and optional parts for customers to choose: remote control, Centralized lubrication, rear view camera etc.

## General Dimension

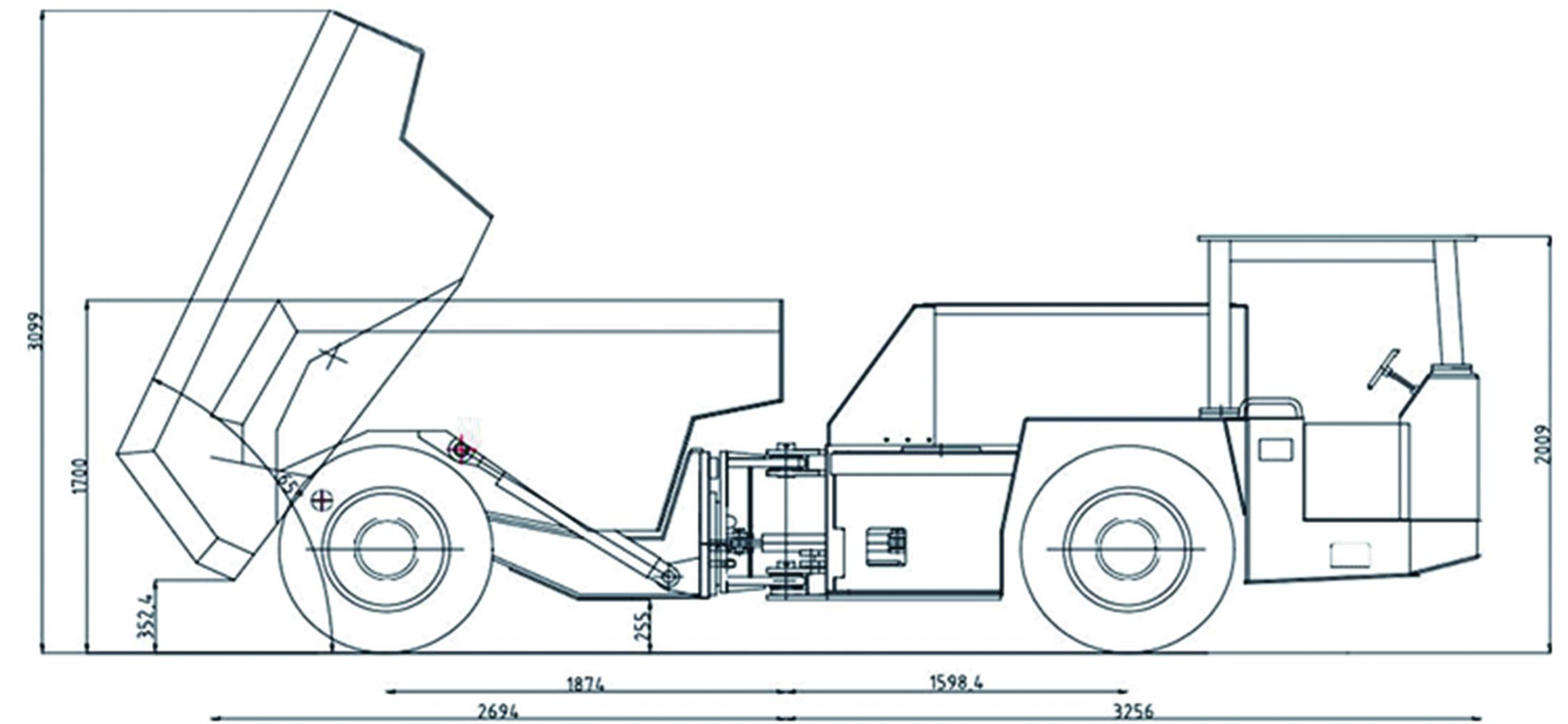



# FUK-6 Underground Truck



## Technical Parameters

### Diesel Engine

- Brand ..... Germany DEUTZ
- Model ..... F6L914
- Type ..... Air cooling
- Rated Power ..... 84KW/2300rpm
- Remarks ..... Original Germany Deutz Brand

### Torque Converter

- Brand ..... American DANA
- Model ..... 1201T20321
- Type ..... Integral, mechanical shift

### Shift Transmission

- Brand ..... American DANA
- Model ..... 1201T20321
- Type ..... Integral, mechanical shift

### Hydraulic Pump

- Brand ..... Parker
- Steering pump ..... Parker
- Brake pump ..... Rexroth
- Slippage pump ..... DANA

### Hydraulic Valve

- Work valve ..... Parker
- Steering valve ..... Parker
- Brake valve ..... Wabco
- Prefill valve ..... Mico
- Acceleration valve ..... WILLIAMS

### Axle

- Brand ..... Meitong
- Model ..... QY-150
- Type ..... Rigid planetary transmission axle with NON-SPIN & anti-slip differential

### Braking System

- Type ..... Working brake, Stop brake
- Description ..... Fully enclosed and Multi-disc wet hydraulic brake, Stop with spring brake

### Driver Cabin

- Reinforced with 6mm steel panel ..... YES
- Side-seat layout with good vision ..... YES
- Closed Cabin with air conditioner ..... for optional

### Bucket

- Material ..... Manganese steel
- Baffle ..... Optional

### Electric System

- Working voltage ..... 24V (consisted of two 12v batteries)

### General Parameter

- Rated capacity ..... 6000kg
- Length ..... 7060mm
- Width ..... 1500mm
- Height(cabin) ..... 2009mm
- Bucket volume ..... 3 m<sup>3</sup>
- Discharging height ..... 3099mm
- Discharging angle ..... 62°
- Bucket lifting time ..... 7 S
- Bucket down time ..... 6 S
- Wheelbase ..... 3472mm
- Min. Ground clearance ..... 255mm
- Min. Turning radius ..... inner 3842.5mm
- Min. Turning radius ..... Outer 5649.8mm

### Loader Weight and Load Capacity

- Truck weight ..... 8000 kg
- Loading weight ..... 14000 kg

### Traveling Performance

- 1 shift forward/backward ..... 5 km/h
- 2 shift forward/backward ..... 11 km/h
- 3 shift forward/backward ..... 19 km/h
- Grade ability ..... 25% (load)
- Max. Traction ..... 124 KN

### Hydraulic System Pressure

- Working system, rated pressure ..... 14 MPa
- Steering system, rated pressure ..... 14 MPa
- Brake system, rated pressure ..... 12.5 MPa

### Tyre

- Model ..... 14.00-24

### Hydraulic System

- Type ..... Working system, steering system braking system, Oil filling and acceleration system

### Hydraulic Cylinder

- Acceleration cylinder ..... WILLIAMS

### Lubrication System

- Manual lubrication ..... YES
- Centralized lubrication ..... For optional

### Fire System

- Manual Fire extinguisher ..... YES
- Centralized Fire extinguisher ..... For optional

### Control system

- Manual control ..... YES