



FOCOR FUK-12 Underground Truck



Main Features

- Main parts are imported top brand, like Deutz Engine, DANA torque converter, transmission, Parker pump and valves etc.;
- Braking System consisted of Working brake and Stop brake, with Fully enclosed and Multi-disc wet hydraulic brake, Stop brake with spring brake;
- Tailor made size and optional parts for customers to choose: remote control, Centralized lubrication, rear view camera etc.

General Dimension

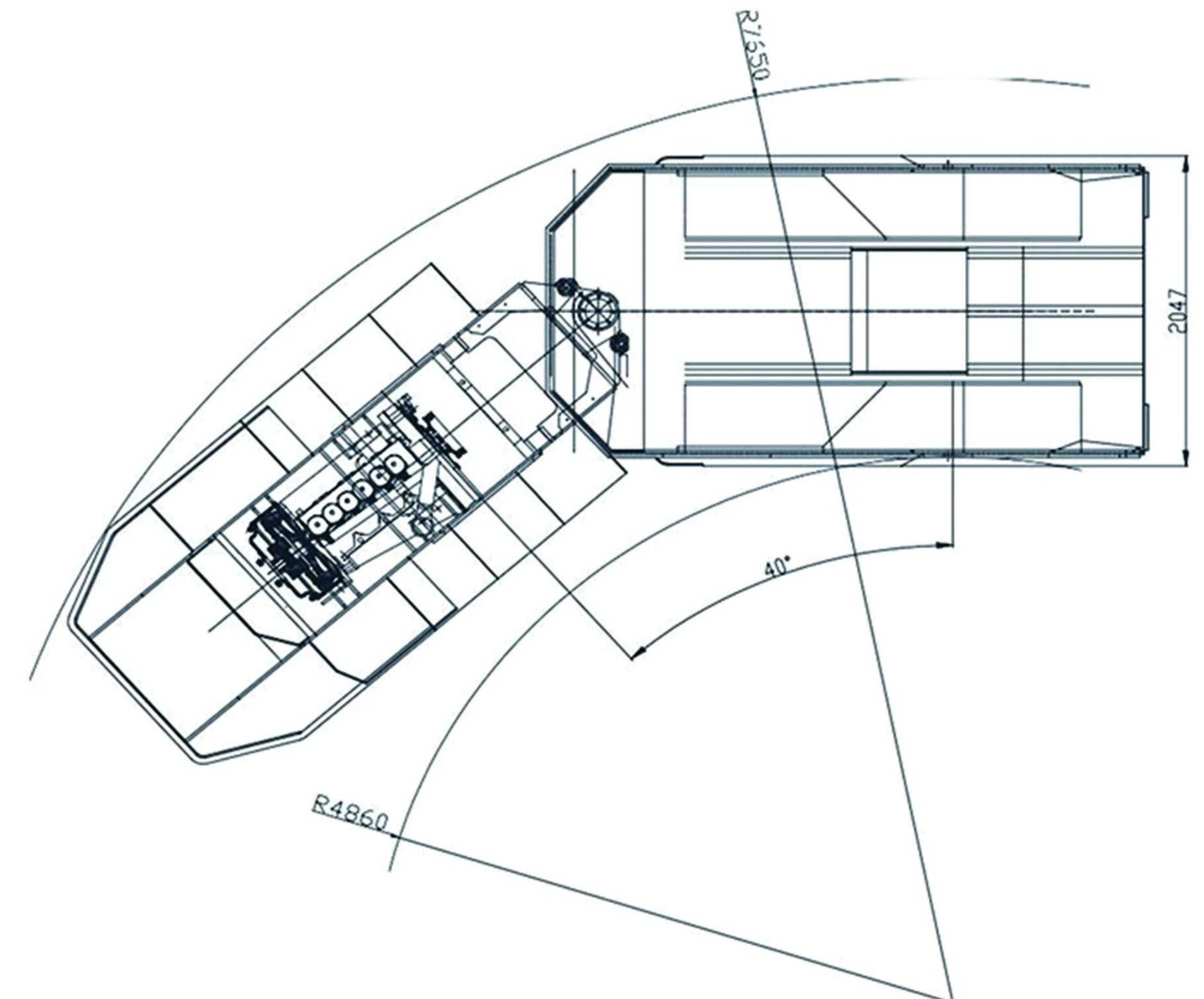
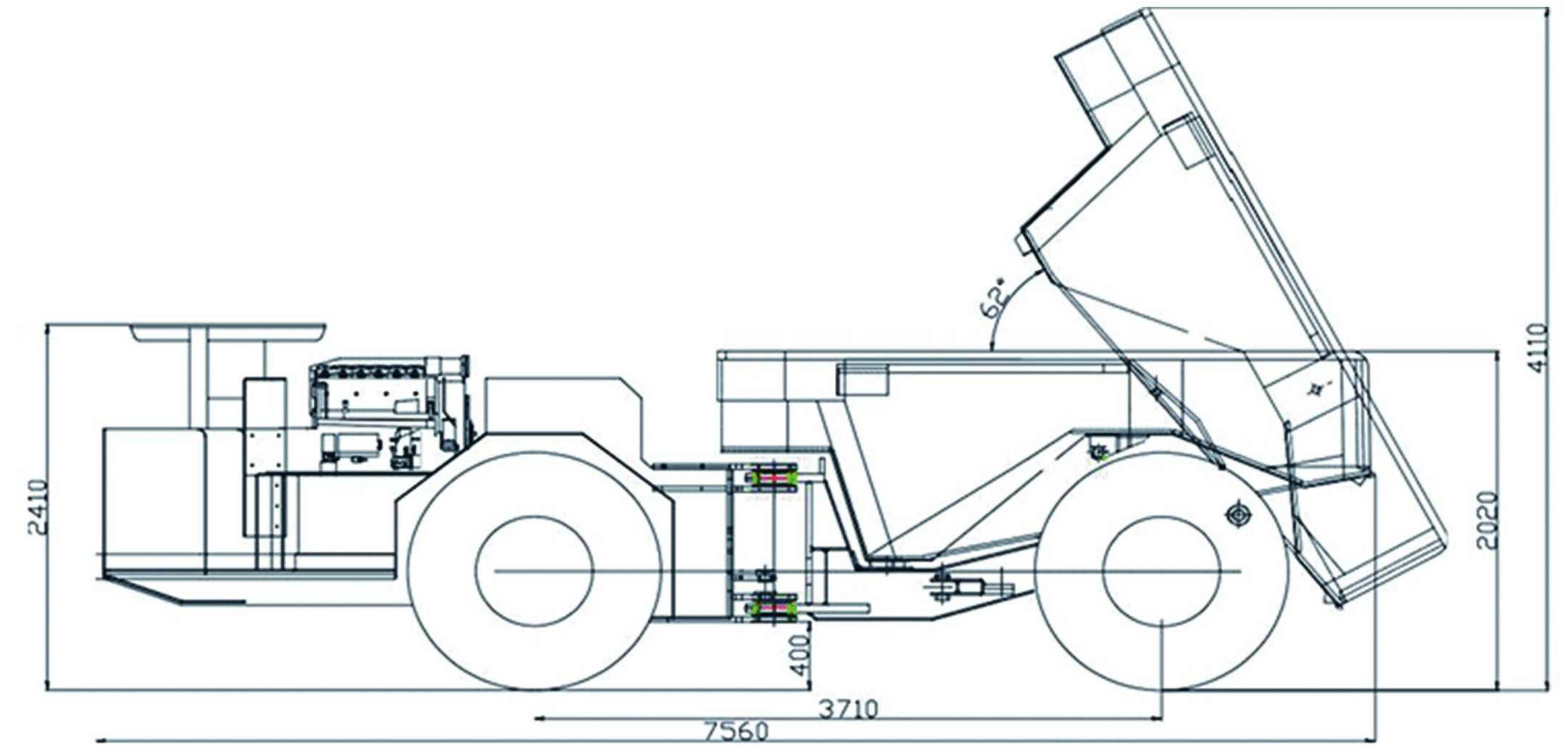

FUK-12 Underground Truck



Technical Parameters

Diesel Engine

- Brand ... Germany DEUTZ
- Model ... BF6M1013FW
- Type ... Water cooling
- Rated Power ... 165KW/2300rpm
- Remarks ... Original Germany Deutz Brand

Torque Converter

- Brand ... American DANA
- Model ... C270
- Type ... Single stage two components with hydraulic pump drive.

Shift Transmission

- Brand ... American DANA
- Model ... R32000
- Shift ... power shift (4 shifts) forward+backward with Emergency brake

Hydraulic Pump

- Brand ... Parker
- Steering pump ... Parker
- Brake pump ... Rexroth
- Slippage pump ... DANA

Hydraulic Valve

- Work valve ... Parker
- Steering valve ... Parker
- Brake valve ... Wabco
- Prefill valve ... Mico
- Acceleration valve ... WILLIAMS

Axle

- Brand ... Meichi
- Model ... QY-150
- Type ... Rigid planetary transmission axle with NON-SPIN & anti-slip differenti

Braking System

- Type ... Working brake, Stop brake
- Description ... Fully enclosed and Multi-disc wet hydraulic brake, Stop with spring brake

Driver Cabin

- Reinforced with 6mm steel panel ... YES
- Side-seat layout with good vision ... YES
- Closed Cabin with air conditioner ... for optional

Bucket

- Material ... Manganese steel
- Ejector Bucket ... For optional

Electric System

- Working voltage ... 24V (consisted of two 12v batteries)

General Parameter

- Rated capacity ... 12000kg
- Length ... 7560mm
- Width ... 2047mm
- Height(cabin) ... 2410mm
- Bucket volume ... 6 m³
- Discharging height ... 4110mm
- Discharging angle ... 62°
- Bucket lifting time ... 11 S
- Bucket down time ... 10 S
- Wheelbase ... 3710mm
- Min. Ground clearance ... 400mm
- Steering angle ... left/right 40°
- Turning angle ... ±10°
- Min. Turning radius ... inner 4860mm
- Min. Turning radius ... Outer 7650mm

Loader Weight and Load Capacity

- Truck weight ... 14500 kg
- Loading weight ... 26500 kg

Traveling Performance

- 1 shift forward/backward ... 5 km/h
- 2 shift forward/backward ... 11 km/h
- 3 shift forward/backward ... 17 km/h
- 4 shift forward/backward ... 22.5 km/h
- Grade ability ... 25% (load)
- Max. Traction ... 160 KN

Hydraulic System Pressure

- Working system, rated pressure ... 14 MPa
- Steering system, rated pressure ... 14 MPa
- Brake system, rated pressure ... 12.5 MPa

Tyre

- Model ... 12.00-24

Hydraulic System

- Type ... Working system, steering system braking system, Oil filling and acceleration system

Hydraulic Cylinder

- Acceleration cylinder ... WILLIAMS

Lubrication System

- Manual lubrication ... YES
- Centralized lubrication ... For optional

Fire System

- Manual Fire extinguisher ... YES
- Centralized Fire extinguisher ... For optional

Control system

- Manual control ... YES