

FOCOR FUK-30 Underground Truck



Main Features

- Main parts are imported top brand, like Deutz Engine, DANA torque converter, transmission, Parker pump and valves etc.;
- Braking System consisted of Working brake and Stop brake, with Fully enclosed and Multi-disc wet hydraulic brake, Stop brake with spring brake;
- Tailor made size and optional parts for customers to choose: remote control, Centralized lubrication, rear view camera etc.

General Dimension

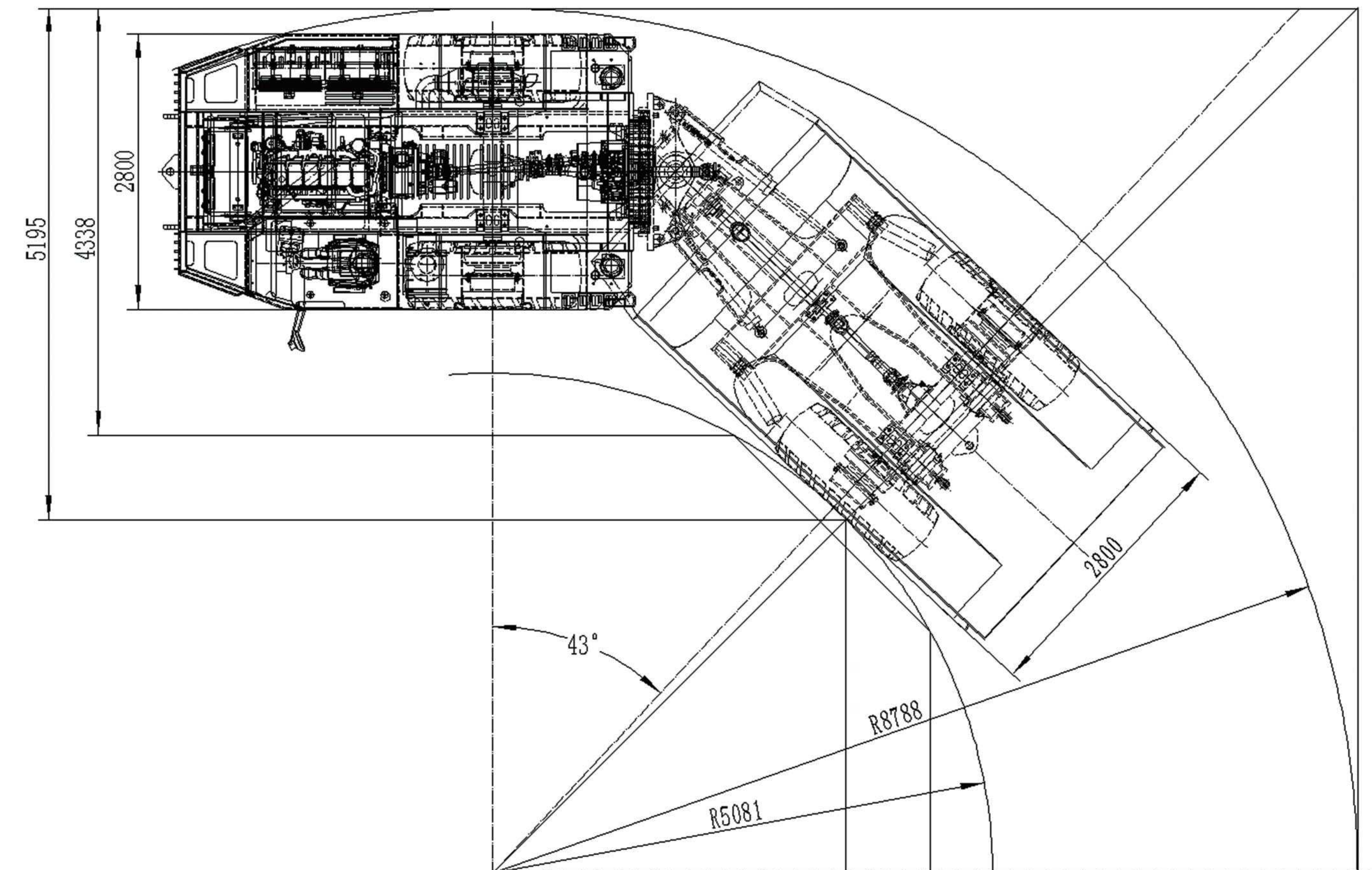
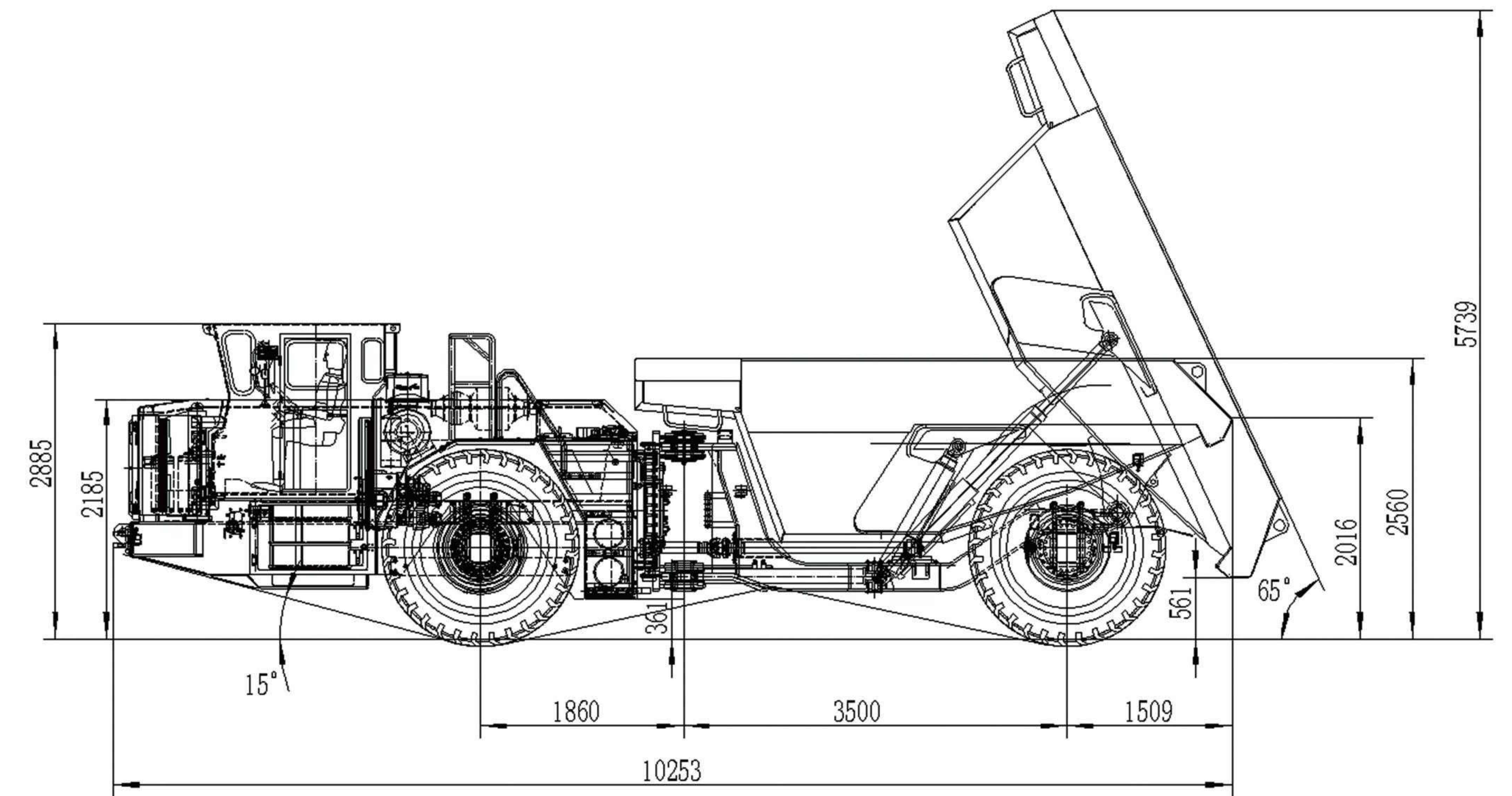

FUK-30 Underground Truck



Technical Parameters

Diesel Engine

- Brand.....VOLVO
- Model.....TAD1351VE
- Type..... Water cooling with 6 cylinders
- Rated Power..... 285KW/1900rpm
- Oil consumption..... 42L/h

Torque Converter

- Brand..... American DANA
- Model..... C800

Shift Transmission

- Brand..... American DANA
- Model..... R8000

Hydraulic Pump

- Brand..... Parker
- Steering pump..... Parker
- Brake pump..... Rexroth
- Slippage pump..... DANA

Hydraulic Valve

- Work valve..... Parker
- Steering valve..... Parker
- Brake valve..... Wabco
- Prefill valve..... Mico
- Acceleration valve..... WILLIAMS

Axle

- Brand..... DANA
- Model..... D91/20D
- Angle of oscillation(front axle)..... ±9°

Braking System

- Type..... Working brake, Stop brake
- Description..... Fully enclosed and Multi-disc wet hydraulic brake , Stop with spring brake

Driver Cabin

- Reinforced with 6mm steel panel.....YES
- Side-seat layout with good vision.....YES
- Closed Cabin with air conditioner..... YES

Bucket

- Material..... Manganese steel
- Baffle..... For optional

Electric System

- Working voltage..... 24V (consisted of two 12v batteries)
- Illumination..... Front lamp 2pcs, 18W,24V

Control system

- Manual control.....YES
- Remote control / Video control..... For Optional

General Parameter

- Rated capacity.....30000kg
- Length.....10253mm
- Width..... 2800mm
- Height(cabin)..... 2855mm
- Bucket volume..... 15 m³
- Discharging height..... 5730mm
- Discharging angle..... 61°
- Bucket lifting time..... 16.1 S
- Bucket down time..... 13.2 S
- Steering time..... 7.5 S
- Wheelbase..... 5185mm
- Min. Ground clearance..... 450mm
- Steering angle..... left/right 44°
- Min. Turning radius..... inner 5081mm
- Min. Turning radius..... Outer 8788mm

Loader Weight and Load Capacity

- Truck weight.....28900 kg
- Loading weight..... 58900 kg

Traveling Performance

- 1 shift forward/backward..... 6.2km/h
- 2 shift forward/backward..... 10.7 km/h
- 3 shift forward/backward..... 18.3 km/h
- 4 shift forward/backward.....30.6 km/h
- Grade ability..... 15% (load)
- Max. Traction..... 300 KN

Hydraulic System Pressure

- Working system, rated pressure..... 14 MPa
- Steering system, rated pressure..... 14 MPa
- Brake system, rated pressure..... 12.5 MPa

Tyre

- Model..... 22.00-3.0

Hydraulic System

- Type..... Working system, steering system braking system, Oil filling and acceleration system

Hydraulic Cylinder

- Acceleration cylinder.....WILLIAMS

Lubrication System

- Manual lubrication..... YES
- Centralized lubrication..... For optional

Fire System

- Manual Fire extinguisher..... YES
- Centralized Fire extinguisher..... For optional